

## Errata

**Title & Document Type:** 1116A Test Mobile Assembly Instructions

**Manual Part Number:** 1116A-900

**Revision Date:** January 1996

### About this Manual

We've added this manual to the Agilent website in an effort to help you support your product. This manual provides the best information we could find. It may be incomplete or contain dated information, and the scan quality may not be ideal. If we find a better copy in the future, we will add it to the Agilent website.

### HP References in this Manual

This manual may contain references to HP or Hewlett-Packard. Please note that Hewlett-Packard's former test and measurement, life sciences, and chemical analysis businesses are now part of Agilent Technologies. The HP XXXX referred to in this document is now the Agilent XXXX. For example, model number HP8648A is now model number Agilent 8648A. We have made no changes to this manual copy.

### Support for Your Product

Agilent no longer sells or supports this product. You will find any other available product information on the Agilent Test & Measurement website:

[www.agilent.com](http://www.agilent.com)

Search for the model number of this product, and the resulting product page will guide you to any available information. Our service centers may be able to perform calibration if no repair parts are needed, but no other support from Agilent is available.

# **hp** MODEL AC-115B TESTMOBILE ASSEMBLY INSTRUCTIONS

- 1) Remove the hands clamping the packed dolly parts.
- 2) Unpack the basket and oscilloscope support frame.
- 3) Remove the two locking collars from the support rods of the basket. An allen wrench is supplied taped to the basket.
- 4) Spread the legs so the basket support rods will fit in the mating holes on the front and rear cross bars.
- 5) Install a locking collar at the left front and right rear basket support bracket below the cross bar. Tighten the set screws securely with the allen wrench. This prevents the basket from accidentally being knocked out of the cross bar holes which would allow the legs to collapse.
- 6) Remove the screws and rubber bumpers from the oscilloscope support frame and install on the dolly top bar. Engage the tilt position bar in the desired holes.

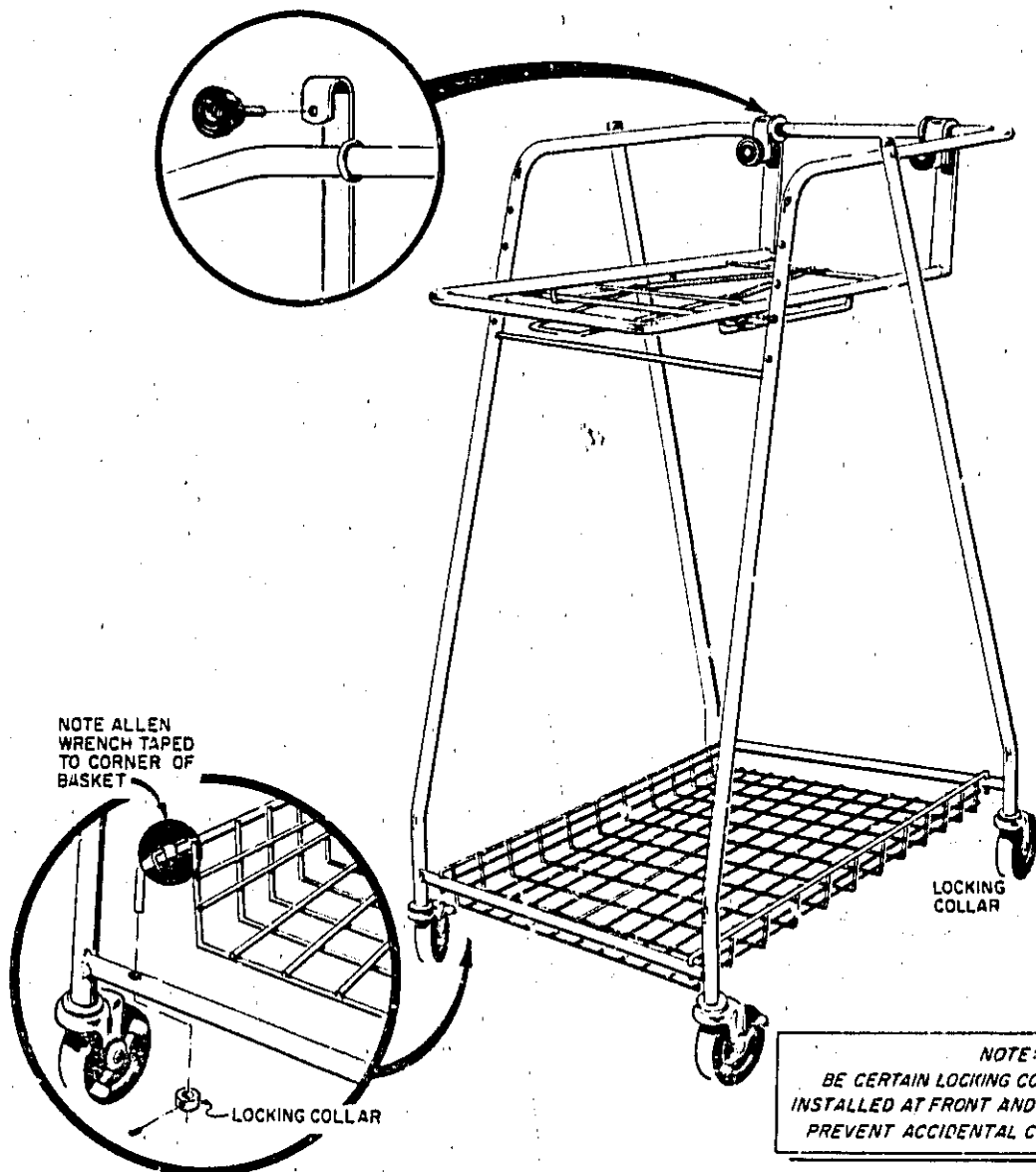

HEWLETT-PACKARD COMPANY 1501 PAGE MILL ROAD, PALO ALTO, CALIFORNIA, U.S.A.

Part Number: 1116A-900